

Peru is one of the most seismically active countries around the world to be located in The "Ring of Fire", and in the edge of two plate tectonics: the Nazca and the South American plates. More than seven years ago, Peru's Ica region was hit by a massive earthquake. The quake affected especially areas where did not exist neither culture of risk management nor urban planning policies; these are some characteristics of informal settlements that surround the cities of the developing countries. After the disaster, the most critical problems which affected population were the access to water and sewerage infrastructure, and the access to decent and safe home. In this context, the Basic Habitability Cooperation Group decided to develop a participatory building project to improve housing conditions of the affected population. Our project promoted the design and construction of earthquake resistant houses and a nursery school, that would be safe, affordable, easily to put together and that would meet the needs of families. The main idea was to combine modern architectural techniques with popular wisdom and local natural resources -such as wood, bamboo and reeds-, to design structures with potential to save lives. The construction system used was: QUINCHA MEJORADA (wall made of wood, reeds and clay), which is a popular technique used since the Viceroyalty.



Panoramic view of one of the human settlements



One of the houses that was constructed by the population



Nursery school's pictures



Construction process's pictures

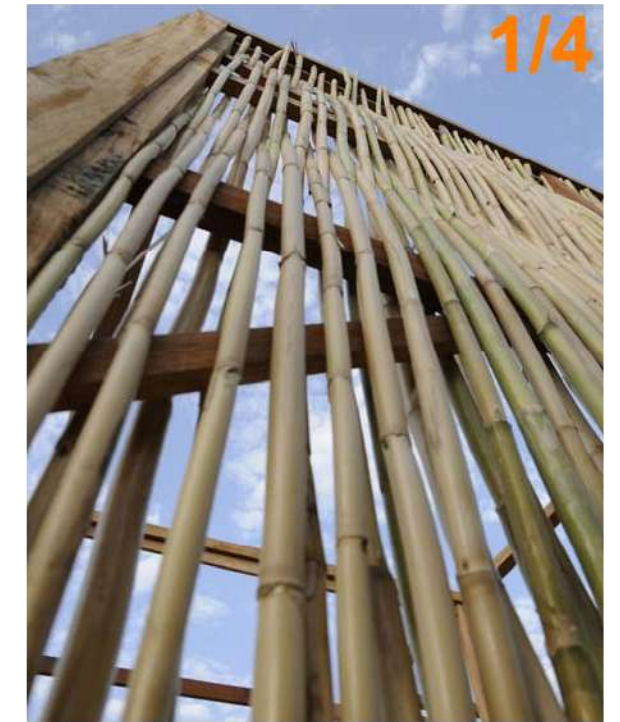

PHYSICAL AND SOCIAL CONTEXT

The context in which we worked is one of the poorest areas in this part of the country. The majority of this population is migrant from the central highlands, most of them, agricultural workers and displaced because of the political violence that they suffered during the 80's and 90's. These communities have settled in the territory by disorderly way and without planning, in so-called poverty belts around the formal city. In Peru, these settlements are called Barriadas. Some of their features are: a) high poverty rates, b) poor physical infrastructure and poor living conditions, c) environmental pollution caused by improper waste management, d) lack of water, and e) informal employment.

These human settlements have become the most dynamic way of occupation of the territories in this area. They are a clear evidence of the self-construction and self-management of the habitat, due to the procedural nature of its growth to improve their poor conditions of life. In these structures both lack of planning as uncontrol of urban sprawl, have generated too many precarious spaces and shortage of social amenities.

CONSTRUCTION SYSTEM: QUINCHA MODULAR

For years, different institutions and NGOs have studied and implemented several technical contributions to improve this construction system, making it safer and cheaper, in comparison to other popular construction techniques. For that reason, it is important to recover this way of building and to meet the current needs of habitat and comfort.

The structure of this improved technique not only has a great strength and rigidity but also has a great flexibility to absorb the seismic wave and not to collapse, thanks to their materials. This technique only needs equipment, materials and easy to use technologies, so there is no risk of technological dependence or waste materials. Therefore, it ensures economic and environmental sustainability.

The construction system is based on a simple concrete foundation with stones and on a structure of wood columns and beams. The floor is made of concrete and the roof is covered with bamboo, reed and clay. The walls are composed of modular wood panels that are plaited with reed and filled with a mixture of cement, sand and gypsum or clay. This technique, similar to a prefabrication system, makes possible a flexible distribution and a progressive construction according to the availability of financial resources and space.

SUPPORT FOR PARTICIPATORY SELF-BUILDING OF FORTY EARTHQUAKE-RESISTANT HOUSES AND ONE NURSERY SCHOOL IN PERU.

María Eugenia Lacarra, architect and member of the Basic Habitability Cooperation Group

WALL PANEL

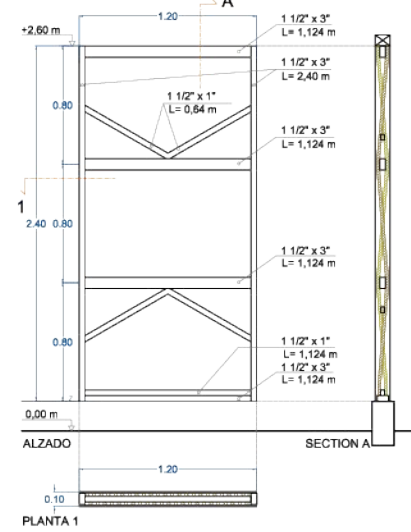

WINDOW PANEL

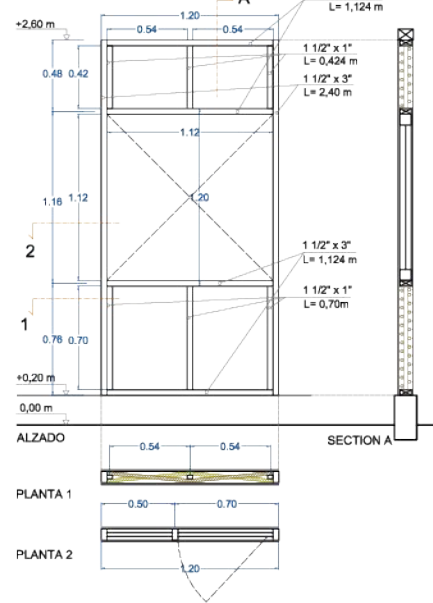

DOOR PANEL

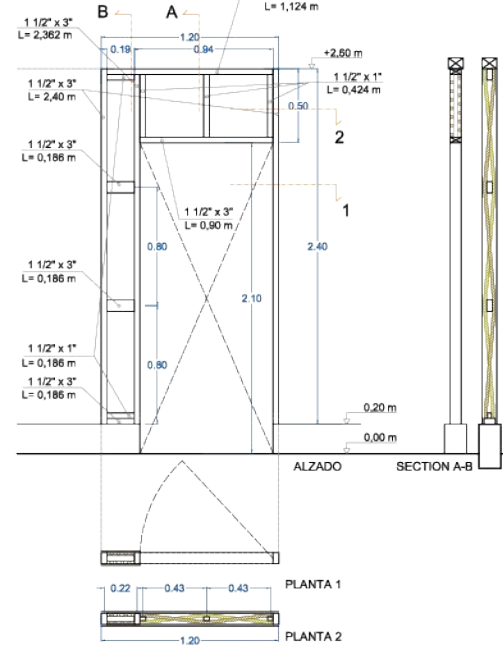

MODULAR WOODEN PANELS
e: 1/50

CONSTRUCTION PROCESS

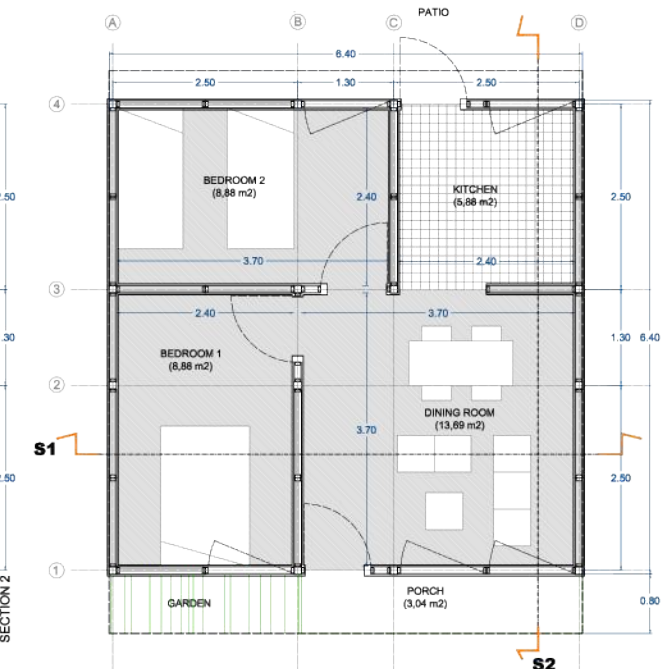
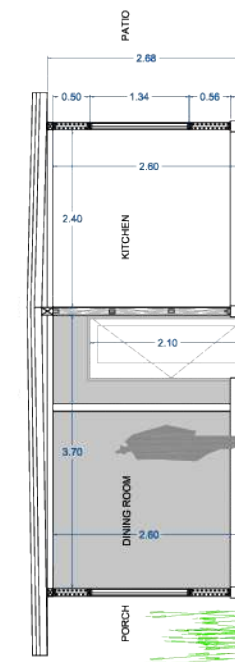
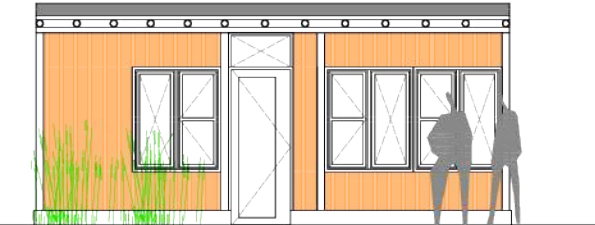
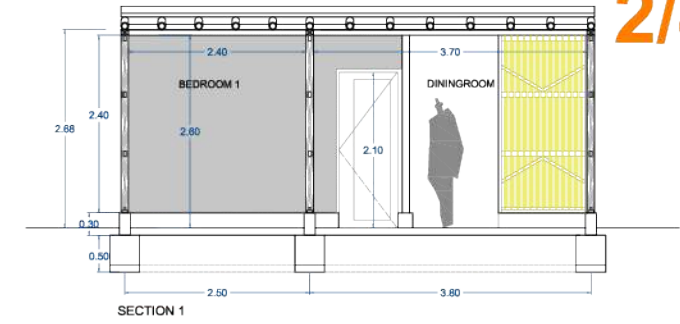
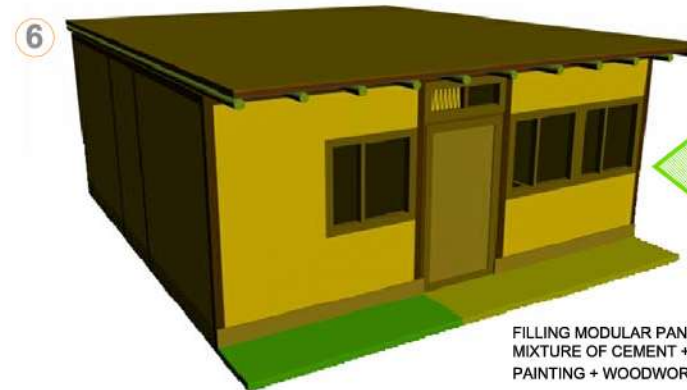
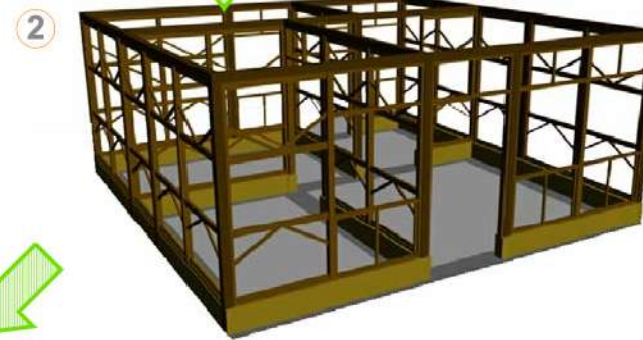
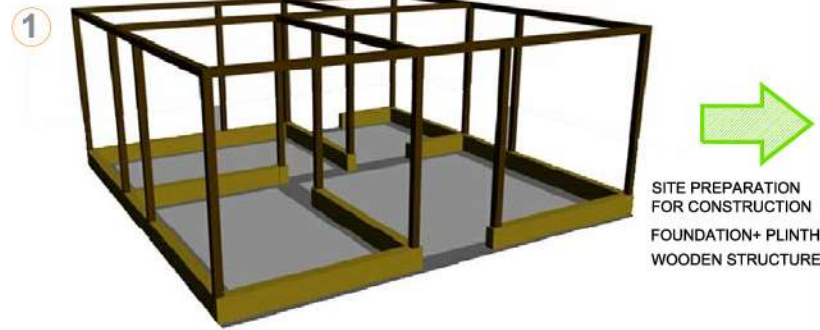

ARCHITECTURAL PLANS: HOUSE TYPE e: 1/100



The design of the houses and the nursery school was based on a study of the culture and tradition of this Peruvian area. It was important for us and for the community to provide the interior comfort through the cross ventilation and with the use of thermally suitable materials. A low-cost construction is not in conflict with architectural construction quality, which is essential for the healthy development of our towns and cities and necessary to improve the quality of life of its inhabitants.

Within the project baseline was the need to provide a home, and not only a single module. This meant that each house should have enough rooms with suitable dimensions to provide basic and decent living conditions.

We consider having the opportunity to develop a housing project that directly benefited the people who most needed it most a success and we are also proud of proposing an alternative option for more environmentally sustainable buildings within the means of local people. The fact that we allowed ourselves a period of time to study the area, its potential, physical characteristics and traditional construction techniques, enabled us to develop a solid proposal which could be justified in every way, be that technical, cultural or environmental.

The community is a subject of law which can contribute to improve their living conditions. The process of empowerment is essential to achieve a fair and inclusive society. Therefore, it is an urgent challenge to strengthen the civic culture and so to achieve concrete actions of responsibility and solidarity between social organizations and local authorities. The concept of social production of habitat is when the communities are the main actors in their development process. They can organize and move people to participate and to decide what they need and how they want to live.

SUPPORT FOR PARTICIPATORY SELF-BUILDING OF FORTY EARTHQUAKE-RESISTANT HOUSES AND ONE NURSERY SCHOOL IN PERU.

María Eugenia Lacarra, architect and member of the Basic Habitability Cooperation Group

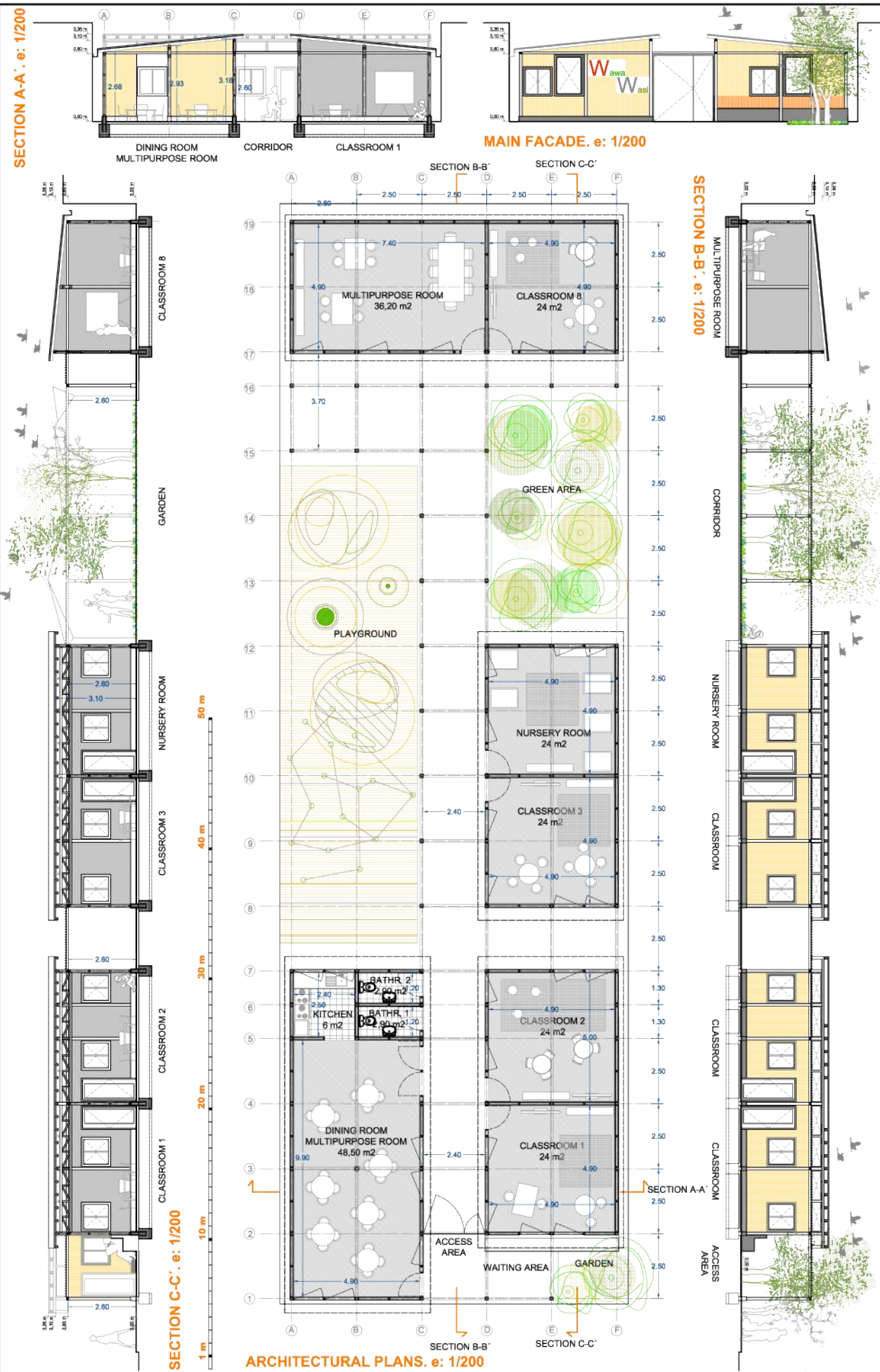

SITE PREPARATION FOR CONSTRUCTION

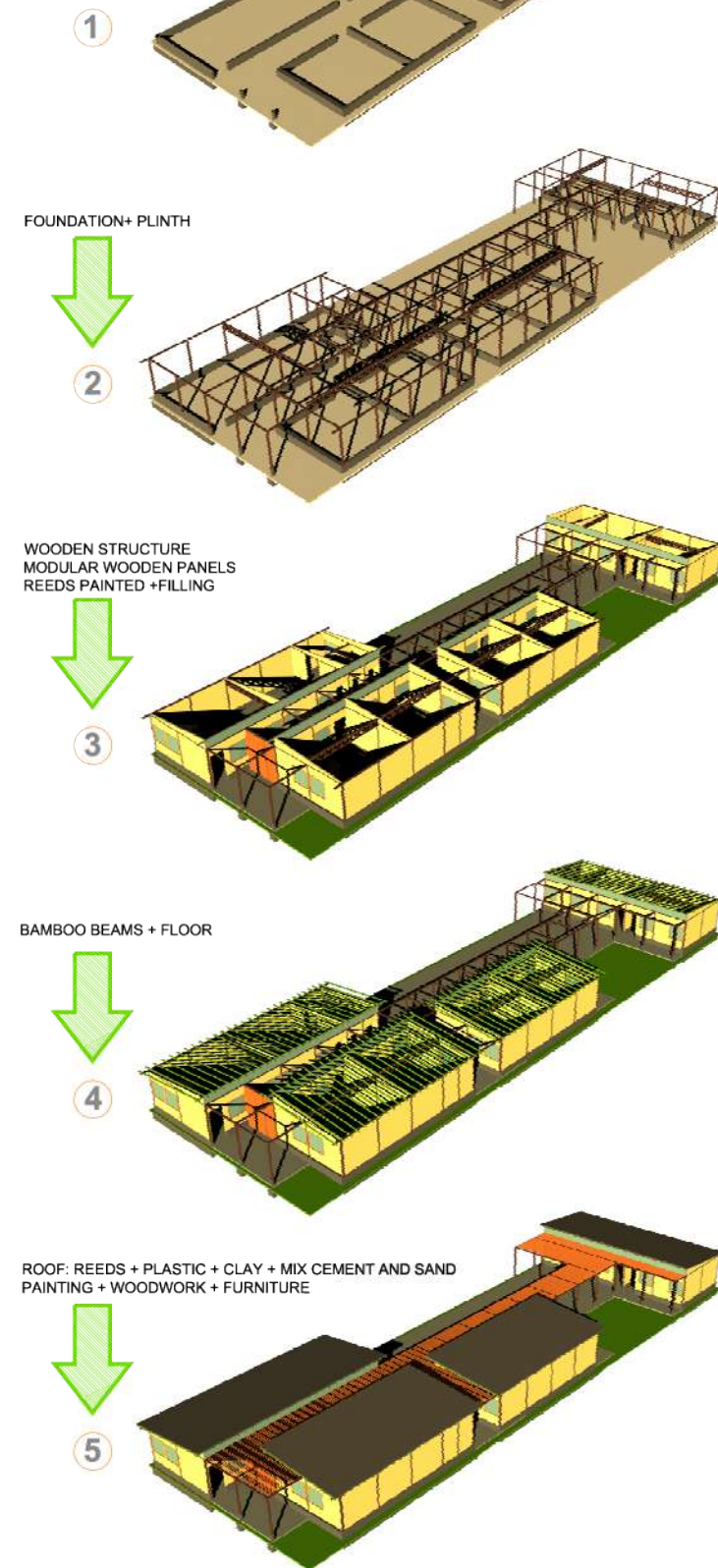

CONSTRUCTION PROCESS

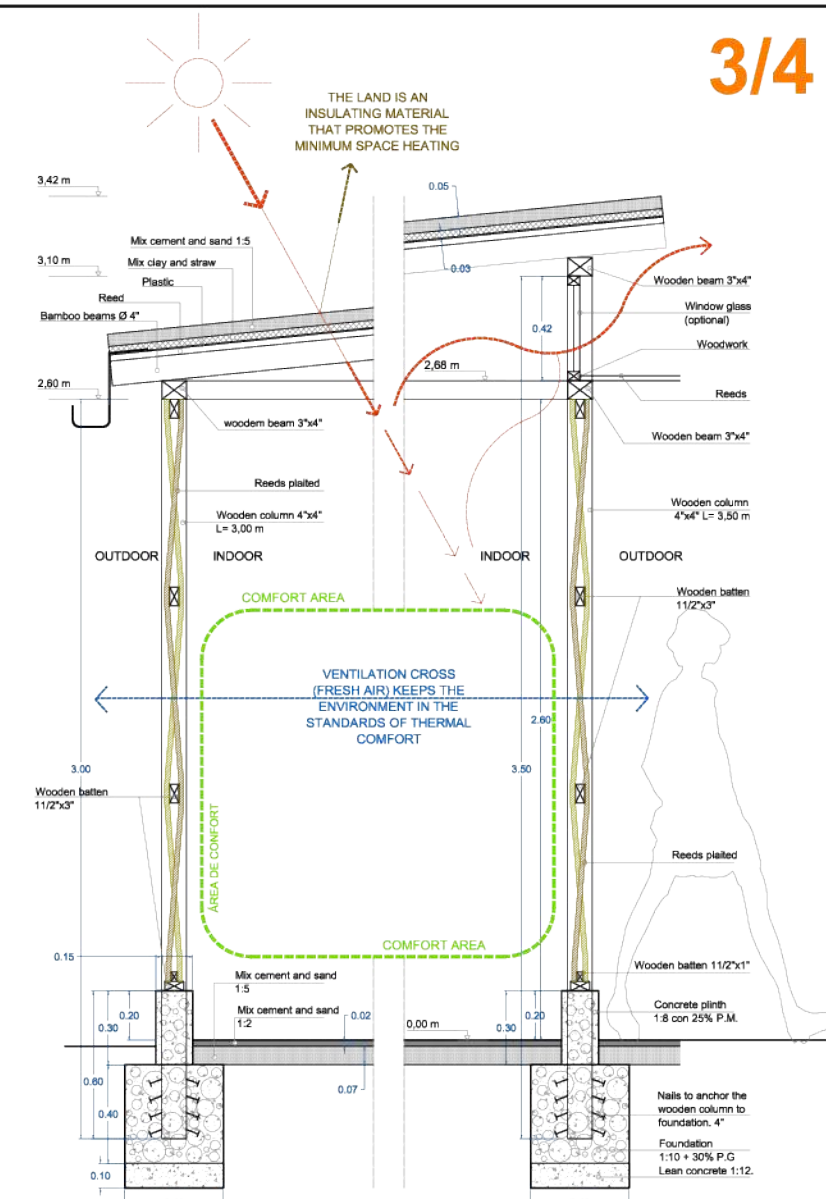

CONSTRUCTION SECTION AND BIOCLIMATIC BEHAVIOR. e: 1/30

The destiny of future generations of Peruvians is a collective task not only the governments but also of families and communities. Children under four years old from the area where we worked did not have their own space for being cared properly (food, education and physical and mental health). Many of them were in a terrible state of neglect while their parents were working. For that reason, the construction of a nursery school was the perfect culmination to all the efforts that were made, favoring who are most in need: children. The early childhood education in a safe and healthy environment, and the development of a personalized learning method appropriate to the social context, were priorities that we could not pass over.

Wawawasi Program (nursery school program in quechua) is a governmental social program to provide comprehensive care (health, nutrition and learning) to early childhood, responding to the need for day care for children under four years. A Community Management Committee organized around the nursery school is responsible for managing the resources allocated by the State to guarantee a proper operation.

The nursery school consists of 4 classrooms, a nursery room, a multipurpose room, a dining room, a kitchen, two bathrooms, green areas and a playground. All the spaces are lighted and ventilated to ensure an adequate climate comfort. The shape of the building was defined by the site where it is located and by the functional needs of this type of educational institution. The slope of the roof helps to expel hot air to the upper layers of the rooms, allowing optimal ventilation and a suitable temperature. Some beneficiaries, who were previously trained during the construction of their own homes, were hired as skilled workers with the full confidence of technical staff.

SUPPORT FOR PARTICIPATORY SELF-BUILDING OF FORTY EARTHQUAKE-RESISTANT HOUSES AND ONE NURSERY SCHOOL IN PERU.

María Eugenia Lacarra, architect and member of the Basic Habitability Cooperation Group



Participatory design workshops



Population supported with their work



The use of local materials in the construction



Women also supported in construction process



Wooden structure was protected against concrete moisture



Wooden columns and beams in houses



Wooden columns and beams in nursery school



Modular panels plaited with reeds



Modular wooden panels that define the space



A participatory and a ludic process for everybody



Roof composed by bamboo, reeds and clay



Roof composed by bamboo, reeds and clay



Thin layer of cement on the walls



Giving color to the urban landscape



"Home sweet home"

All of us have the right to live in a quality house and that is possible through the coordinated work between public and private institutions, grassroots and civil society. Apart from that, we are convinced that for the successful development of this kind of projects in these contexts of poverty and exclusion, it is necessary to incorporate three determinants: THE PARTICIPATION OF THE POPULATION, the USE OF LOW COST/LOCAL MATERIALS AND TECHNIQUES, and the RISK MANAGEMENT EDUCATION.

This experience not only demonstrates that the communities want to participate in their development, but also rescues the great capacity and courage that they have, despite of the level of vulnerability and exclusion in which they live. We strongly believe that the project has contributed to improve their living conditions and that it is a reference about new ways of building.

The growing urban poverty, the expanding of human settlements, the vulnerability of informal communities and the continuous deterioration of the living conditions of the urban population, make necessary that architects devote our efforts to improve the habitat of vulnerable population.

SUPPORT FOR PARTICIPATORY SELF-BUILDING OF FORTY EARTHQUAKE-RESISTANT HOUSES AND ONE NURSERY SCHOOL IN PERU.

María Eugenia Lacarra, architect and member of the Basic Habitability Cooperation Group